

# WIRELESS NET SOUNDER SYSTEM

FOR MID-WATER AND DEEP SEA TRAWLING OPERATIONS

MODEL: TRAWL EXPLORER II

Trawl Explorer II incorporates the latest advances in digital signal processing and software defined technology for increased performance and flexibility.

The underwater wireless sounder is deep sea rated for operating depths to 2,000 metres and a wireless transmission range of 4,000 metres. The sounder uses a unique new rechargeable battery technology that provides battery life of up to 100 hours on a single charge. The sounder's body is constructed from molded polyurethane with an inner sub-frame of marine grade aluminum. Like all Marport sensors, it's designed for the toughest ocean conditions. The sounder digitally processes echo returns to minimize the effects of underwater noise and interference. The data is transmitted via wireless acoustic link to the ship's hydrophone.

The hydrophone is networked to an all-new multi-band acoustic receiver for enhanced signal detection and demodulation. The receiver encodes and transfers the data to a bridge processing computer using Ethernet networking. On the computer, Marport's CommandView software presents high resolution visualization of net behavior and fish density in and around the net. The software has a customizable display to allow a combination of net sounder and trawl sensor gauges in digital, analog and scientific formats.

The receiver and bridge equipment can process and display data from both the net sounder plus up to 37 different Marport net monitoring sensors (catch, door spread, door angle, speed, etc.) Also support net sensors from other manufacturers.

Due to the sounder's position on the head-rope, highly accurate measurements can be made. It displays trawl opening height, clearance to the bottom, water temperature and the presence of fish over, under and in the trawl. The system supports six different display modes: Down Only, Up Only, Simultaneous Up/Down, Double Down (dual frequency), True Motion and History.

The all digital system has a data store/replay function that eliminates the need for paper printouts as the digital echograms are recorded on the bridge computer's hard disk. The system can store hundreds of hours of date/time-stamped raw echogram data as well as all navigation data such as lat/long, COG, SOG, etc. The target strength dB level of each echogram pixel is also recorded.

The system's open architecture design can easily input and output data with other applications via NMEA 0183 and TCP/IP networking. Supports the HAC fisheries acoustic data exchange format.

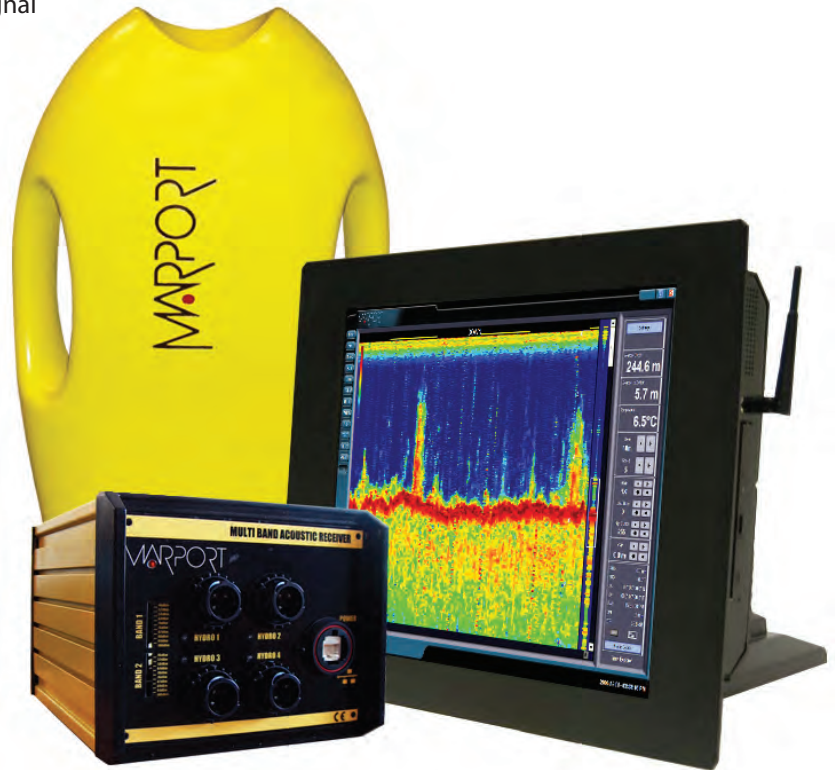

# TRAWL EXPLORER II SYSTEM SPECIFICATIONS

## 1. WIRELESS NET SOUNDER

<b>OPERATING DEPTH</b>	2000 m	
<b>SOUNDING</b>		
Frequency:	96 kHz	210 kHz
Beam Width (at -3db):	25°/45°	20°
Output:	100W	100W
Detection Range:	640m	200m
Sounding Direction:	Upward, Downward and Dual Down	
Range Up/Down:	80/160/320/640m	
Vertical Resolution:	0.002 - 1.5 m	
Transmission Line:	0.25 m	
Acoustic Interference:	None	

### TEMPERATURE SENSOR

Sensor Range:	-5 - 40° C
Sensor Accuracy:	+/- 0.1° C

### DEPTH SENSOR

Sensor Range:	0 - 2000 m
Sensor Accuracy:	1.5 m

### DATA TRANSMISSION TELEMTRY

Frequency Range:	27 - 56 kHz	
Mode of Signal:	FSK for synchronization, FM for data	
Beam Width:	70°	
Output:	1 - 10 W	
Update Rate:	0.9 - 1.6 s	
Range to Vessel:	3800 m (33 kHz)	} at 2.4 W output
	3000 m (40 kHz)	
	2200 m (50 kHz)	
	4500 m (33 kHz)	} at 10 W output
	3600 m (40 kHz)	
	2800 m (50 kHz)	

### POWER SUPPLY

Battery Type:	Li-ion 7.4 V 13.6 Ah
Operating Time:	16 - 100 hrs
(depending on output power)	
Charging Time:	5 hrs

### PHYSICAL MEASUREMENTS

Length:	511 mm
Width:	269 mm
Height:	139 mm
Weight in Air:	9 kg
Weight in Water:	1.6 kg

## 2. ACOUSTIC RECEIVER

TCP/IP Network Compatible:	Yes
Power over Ethernet:	8 W
Hydrophone Inputs:	4
Hydrophone Power Supply:	Active or Passive
WiFi Ready:	Yes
Acoustic Sensor Channels:	37
Acoustic Net Sounder Channels:	1
Centre Frequency:	10-80 kHz

## 3. PANELPC

LCD Size:	19" / 26"
Resolution:	1280x1024 / 1360x768
Brightness:	250 cd/m <sup>2</sup>
LCD Dimmer:	Yes
Blacklight MTBF:	25 000 hrs
Contrast Ratio:	450:1 (Typ)
View Angle H-V:	130 (H) x 130 (V)
LCD MTBF:	50000 hrs
CPU:	Intel Celeron / Pentium4 / P4-M with FSB 533(3.06G)/ 400(2.2G) MHz
RAM:	DDR 184pin up to 2GB
Input/Output:	4 x COM 1 x VGA 1 x Parallel Port 2 x USB 2.0 Intel 10/100 Mbps Ethernet Intel 10/1000 Mbps Ethernet 1 x CFII 2 x PS/2 Keyboard/Mouse 3 x Audio Port (1 x Mic-in, 1 x Line-in and 1 x Line-out)
HDD Drive Bay:	Two 2.5" internal HDD
FDD Drive Bay:	1 Slim type FDD
CD-ROM Drive Bay:	1 Slim type Combo drive
Construction front panel:	Aluminum

## TRAWL EXPLORER II SYSTEM OVERVIEW

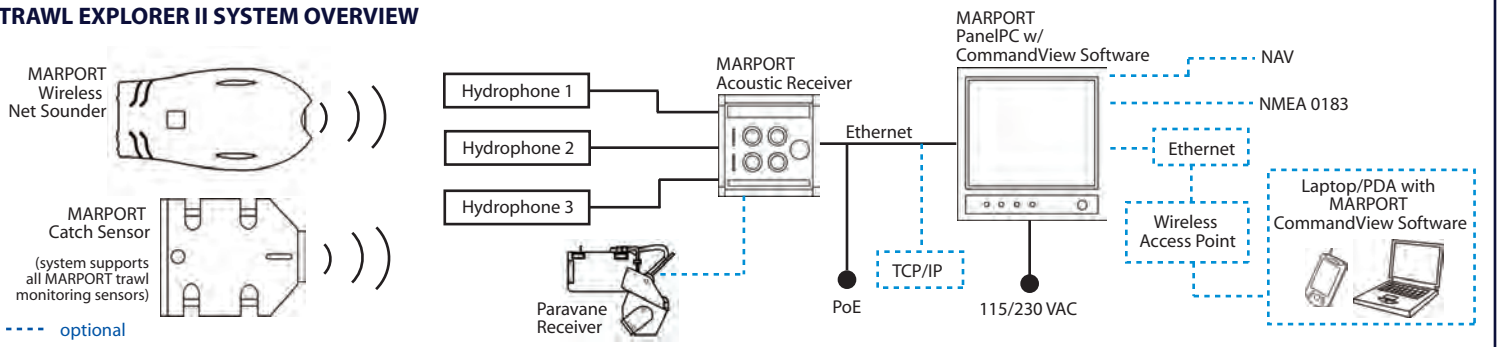

Note: Technical specifications subject to change without notice.

Copyright © 2006. Marport Canada Inc. All Rights Reserved.

All brand, product and company names mentioned herein are trademarks or registered trademarks of their respective owners. Marport reserves the right to alter product offerings and specifications at any time without notice, and is not responsible for typographical or graphical errors that may appear in this document.